

VEGAPULS C 11

Two-wire 4 ... 20 mA

Radar sensor for continuous level measurement



Application area

The VEGAPULS C 11 is the ideal radar sensor for non-contact level measurement in all standard applications where a high degree of protection is required. It is particularly suitable for level measurement in water treatment, pumping stations and rain overflow basins, for flow measurement in open channels and level monitoring and for many other industrial applications.

The sensor is suitable both for measuring liquids and for maintenance-free use on small bulk silos or bulk solids containers.

Your benefit

- Maintenance-free operation due to non-contact 80 GHz radar technology
- Exact measuring results independent of product, process and ambient conditions
- Low-cost sensor for simple measuring tasks

Function

The sensor emits a continuous radar signal through the antenna. The emitted signal is reflected by the medium and received as an echo by the antenna.

The frequency difference between the emitted and received signal is proportional to the distance and depends on the filling height. The determined filling height is converted into a respective output signal and output as measured value.

Technical data

Measuring range up to	8 m (26.25 ft)
Deviation	≤ 5 mm
Beam angle	8°
Measuring frequency	W-band (80 GHz technology)
Output signal	4 ... 20 mA
Process fitting	Thread G1½, 1½ NPT, R1½
Mounting connection	Thread G1, 1 NPT, R1
Process pressure	-1 ... 3 bar (-100 ... 200 kPa/-14.5 ... 43.51 psig)
Process temperature	-40 ... +60 °C (-40 ... +140 °F)
Ambient temperature	-40 ... +60 °C (-40 ... +140 °F)
Bluetooth standard	Bluetooth 5.0 (downward compatible to Bluetooth 4.0 LE)
Effective range Bluetooth typ.	25 m (82 ft)
Operating voltage	12 ... 35 V DC
Protection rating	IP66/IP68 (3 bar) acc. to IEC 60529, Type 6P acc. to UL 50

Materials

The wetted parts of the instrument are made of PVDF. The process seal consists of FKM. The connection cable is PVC insulated.

A complete overview of the available materials and seals can be found on our homepage under "Products" and "Configure & Order".

Housing versions

The housing is optimized for applications in the water/waste water industry and manufactured of PVDF. Due to the encapsulated cable gland, protection rating IP66/IP68 (3 bar) is achieved.

Electronics versions

The devices are constructed with two-wire electronics 4 ... 20 mA.

Approvals

Worldwide approvals are available for VEGA instruments, e.g. for use in hazardous areas, on ships or in hygienic applications.

The technical data in the respective safety instructions are valid for approved instruments (e.g. with Ex approval). In some cases, these data can differ from the data listed herein.

You can find detailed information on the existing approvals with the appropriate product on our homepage.

Adjustment

Wireless adjustment via Bluetooth

The Bluetooth version of the device enables wireless connection to smartphones/tablets (iOS/Android) or Windows PCs.



Wireless connection to standard operating devices

Operation is via a free app from the "Apple App Store", the "Google Play Store" or the "Baidu Store". Alternatively, adjustment can also be carried out via PACTware/DTM and a Windows PC.

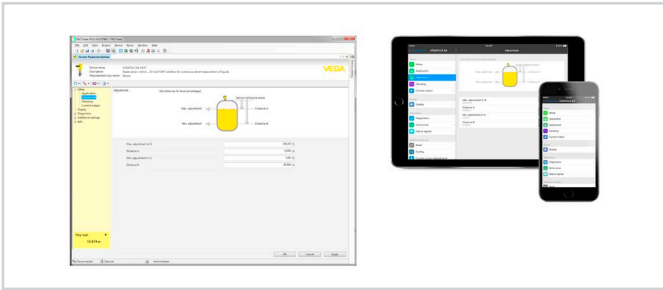

Adjustment via PACTware or app

Electrical connection



Wire assignment in permanently connected connection cable

- 1 Brown (+) to voltage supply or to the processing system
- 2 Blue (-) to voltage supply or to the processing system

You can find details on electrical connection in the instrument operating instructions at www.vega.com/downloads.

Dimensions

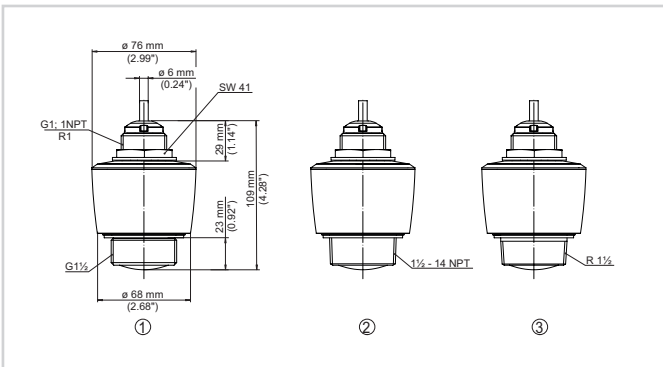

Dimensions VEGAPULS C 11

- 1 Thread G1½
- 2 Thread 1½ NPT
- 3 Thread R1½

Mounting accessories

For the VEGAPULS C 11 the suitable mounting accessories for ceiling or wall mounting is available.

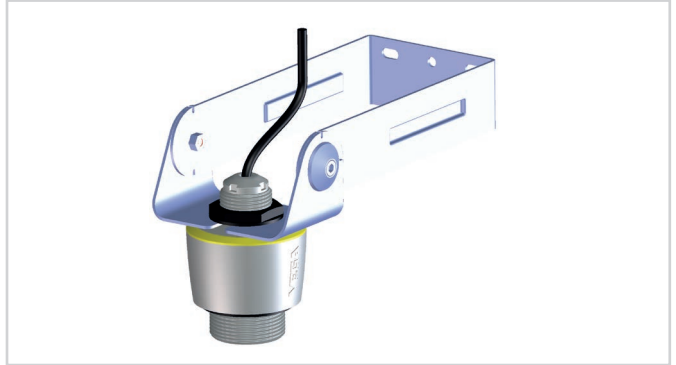

Mounting strap with adjustable sensor holder for sensors with axial cable outlet - Wall mounting (example)

You can find further information on the mounting accessory on our homepage.

Information

You can find further information on the VEGA product line on our homepage.

In the download section on our homepage you'll find operating instructions, product information, brochures, approval documents, instrument drawings and much, much more.

Software accessories such as the current device software and the appropriate operating software are also available there.

Instrument selection

On our homepage under "Products" you can select the suitable measuring principle and instrument for your application.

There you will also find detailed information on the available device versions.

Contact

You can find your personal contact person at VEGA on our homepage under "Contact".